

PERMIT

City of Napoleon
255 W. Riverview
Napoleon, OH 43545

Division of Building and Zoning
PH (419) 592-4010
FAX (419) 599-8393

Permit No: 002253

Date Issued: 06-25-04

Issued by: BND

Job Location: 1005 E RIVERVIEW AVE

Est. Cost: 7500.00

Lot #:

Subdivision Name: FLOOD PLANE

Owner: HAUENSTEIN, TODD
Address: 1005 E RIVERVIEW AVE
CSZ: NAPOLEON, OH 43545
Phone: 419-592-0424

Agent: SELF
Address:
CSZ:
Phone:

Use Type -- Residential:

Other:

ZONING INFORMATION

Dist:	Lot Dim:	Area:	Fyrd:	Syrd:	Ryrd:
Max HT:	# Pkg Spaces:			# Loading SP:	Max Lot Cov:

BOARD OF ZONING APPEALS:

Work Type -- New:	Replmnt:	Add'n:	Alter:	Remodel:
-------------------	----------	--------	--------	----------

WORK INFORMATION

Size - Lgth:	Width:	Stories:	Living Area SF:
Garage Area SF:	Height:	Bldg Vol Demo Permit:	

WORK DESCRIPTION
FOUNDATION PERMIT

FEE DESCRIPTION	PAID DATE	FEE AMOUNT DUE
BUILDING PERMIT	06-25-04	53.00

Total Fees Due 53.00



Date

Applicant Signature

CITY OF NAPOLEON GENERAL PERMIT APPLICATION
THIS APPLICATION IS FOR RESIDENTIAL CONSTRUCTION INCLUDING BUILDING, ELECTRICAL,
PLUMBING, MECHANICAL, DEMILITIONS, REMODELING

Date 6/25/04 Job Location 1005 E RIVERVIEW

Owner TODD HAVENSTEIN Phone 419 592-0424

Owner Address 1005 E. RIVERVIEW City NAPOLEON Zip 43545

Contractor SELF Phone _____

Description of work to be performed BASEMENT FOUNDATION

Estimated cost of work to be performed \$17,500.00

Please indicate the type of work you will be performing by

- | | |
|---|--|
| <input type="checkbox"/> A/C Add On | <input type="checkbox"/> Remodeling |
| <input type="checkbox"/> Boiler Replacement | <input type="checkbox"/> Roofing |
| <input type="checkbox"/> Curbing | <input type="checkbox"/> Sewer Repairs |
| <input type="checkbox"/> Decks | <input type="checkbox"/> Sidewalk |
| <input type="checkbox"/> Driveway | <input type="checkbox"/> Siding |
| <input type="checkbox"/> Electrical Service Upgrade | <input type="checkbox"/> Sign |
| <input type="checkbox"/> Electrical Service New | <input type="checkbox"/> Storage Shed |
| <input type="checkbox"/> Fence | <input type="checkbox"/> Street Bond |
| <input checked="" type="checkbox"/> Foundation | <input type="checkbox"/> Swimming Pool |
| <input type="checkbox"/> Furnace Replacement | <input type="checkbox"/> Temp Electric |
| <input type="checkbox"/> Furnace New | <input type="checkbox"/> Water Tap |
| <input type="checkbox"/> Lawn Meter | <input type="checkbox"/> Windows |
| <input type="checkbox"/> Plumbing | <input type="checkbox"/> Zoning |
| <input type="checkbox"/> Others | |

_____ Permit Number

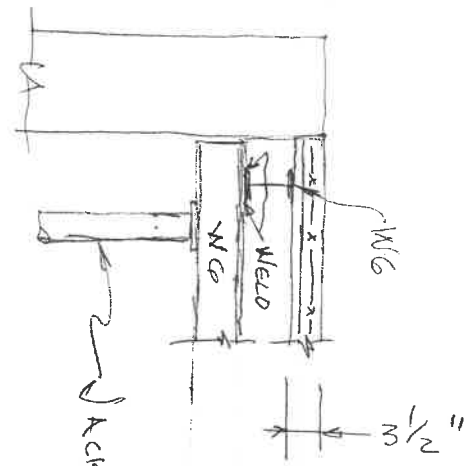

SECTION A-A

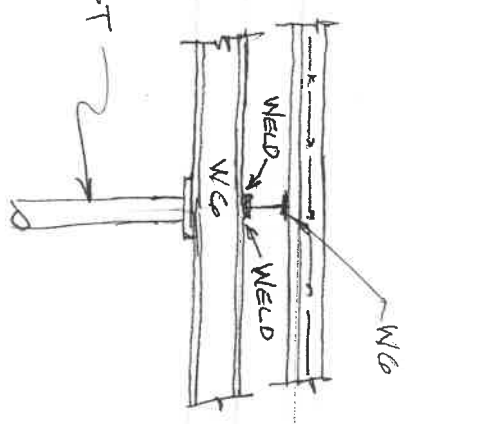

SECTION B-B

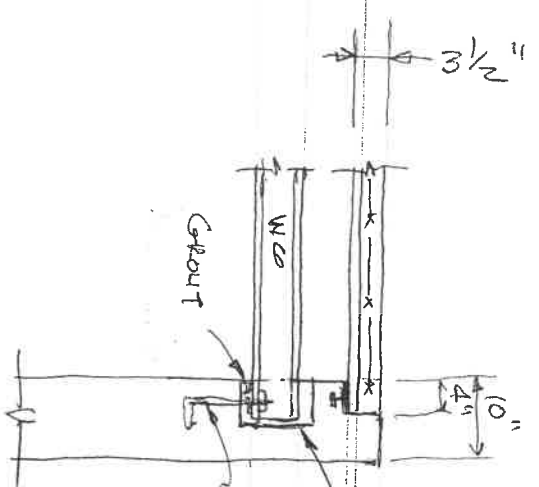

SECTION C-C

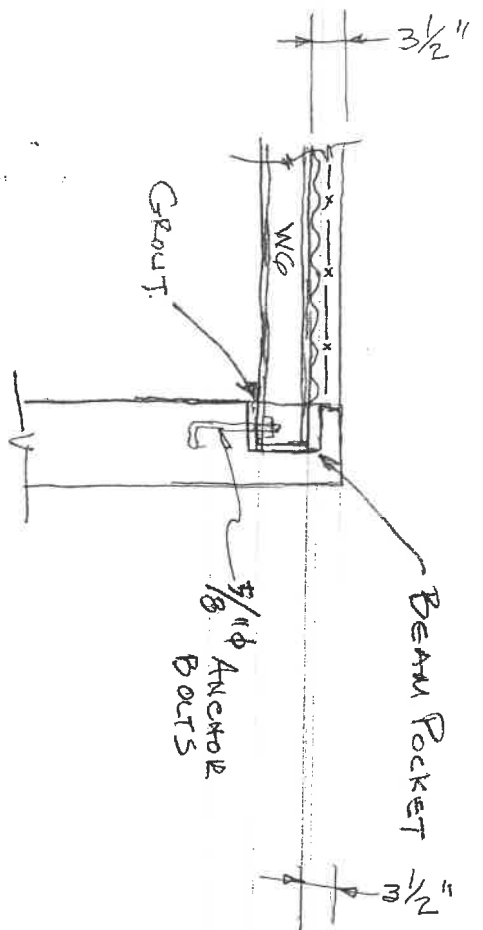

SECTION D-D

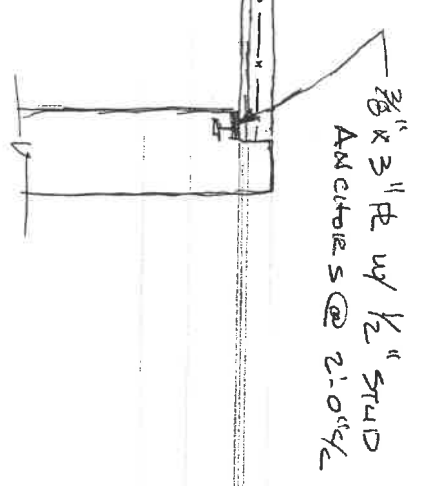

SECTION E-E

F

City of Napoleon Inspection Form

Permit #002253

Date Issued: 06-25-2004

Job Location: 1005 E RIVERVIEW AVE

Owner: HAUENSTEIN, TODD

Owner Phone: 419-592-0424

Contractor: SELF

Contractor Phone:

Work Description: FOUNDATION PERMIT

Plumbing: UNDGR _____ RGHIN _____ FINAL _____

 SEWER INSP _____

Mechanical: UNDGR _____ RGHIN _____ FINAL _____

 FURNACE REPLAC _____ AIR COND _____

Electrical: UNDGR _____ RGHIN _____ FINAL _____

 SEVR UPGR _____

Building: Site _____ FTG 11-05-04 FNDDT 11-19-04

 STRU _____ ROOF _____ EXT _____

 VENT _____ ACCES _____ EGRS _____

 SMKDT _____ FINAL _____

 ISSUE TEMP OCCUP _____ ISSUE OCCUP _____

STGE Shed: SITE _____ FINAL _____

Sign: FTG _____ FINAL _____

Fence: SITE _____ FINAL _____

DRIVEWAY: _____ SIDEWALK: _____

MISC INSP: _____

NOTES:

INSPECTORS INITIALS: _____